



DRYING

SINGLE POCKET DRYERS ADVANCE+ -FD25 TP2 PLUS



CHARACTERISTICS

TP2

- 7" touchscreen, user friendly and totally programmable.
- Videos on display, ads, instructions.
- Free software for programming, telemetry, data analysis.
- USB Connection.
- 37 Languages.
- 8 dosing signals.

OUTSTANDING FEATURES

- Reversing drum action is standard.
- Stainless steel drum is standard.
- Frequency inverter is standard.

EFFICIENCY

- Intelligent humidity control with drum inlet temperature control.
- Efficient air recirculation system.
- Double door glass.
- Optimized system of mixed airflow.

VERSATILITY

- Make to order - customization.
- Wet Cleaning configuration.

CONNECTIVITY

- Standard IoT FagorKconnect.
- Management of laundries: OPL and COIN.

ERGONOMICS

- Lint Filter Drawer, made of stainless steel.
- Large loading doors.

MAINTENANCE

- Hinged panel: easy and ergonomic access.
- Technical menu: statistics for technicians.

OTHERS

- Grey skin plate outer casing, stainless steel look.
- Integrated Fire Extinguishing System.
- Drum with stamped holes.
- Anti-wrinkle at the end of the cycle.
- Heating options: natural gas and propane.
- CE approved.

OPTIONS

- Opposite door opening.
- Tropicalized model.
- Dosing/spraying system.
- Back panel external air + filter.
- Fluff filter with grid 0,02 In (standard is 0,01 In).
- Fluff filter with grid 0.04 In (standard is 0,01 In).
- Stainless steel front and side panels
- Front panel in stainless steel

CAPACITY		FD-25 TP2 PLUS
Capacity 1/18	Kg	11.7
	Lb	25.7
Capacity 1/20	Kg	10.5
	Lb	23.1
DRUM		
Ø Drum	mm	750
	inch	29.53
Drum length	mm	475
	inch	18.7
Drum volume	l cu	210
	ft	7.41
Ø Door	mm	574
	inch	22.6
Floor to door center	mm	976
	inch	38.43
Floor to lower part of the door	mm	618
	inch	24.33
Drum motor power	kW	0.37
ELECTRIC POWER		
Installed heating power	kW	12
Installed electrical power	kW	12.97
Evaporation capacity	l/h	11
	USgallon/h	2.91
Hourly output	Kg/h	21.7
	Lb/h	47.8
GAS POWER		
Installed heating power gas	Kcal/h	17638
	Btu/h	70000
Installed heating power gas	kW	20.51
Installed electrical power	kW	0.97
Instant propane gas consumption (G31)	Kg/h	1.76
	Lb/h	3.88
Instant natural gas consumption (G20)	m³/h	2.17
	cfm	1.28
Evaporation capacity	l/h	15
	USgallon/h	3.95
Hourly output Ø Gas inlet	Kg/h	31.3
	Lb/h	68.9
	BSPP ISO 228-1	1/2"
STEAM POWER		
Installed heating power steam	kW	30
	Btu/h	102364
Installed electrical power	kW	0.97
Steam consumption (8 barG) - Stándar	Kg/h	53
Steam consumption (116 psiG)	Lb/h	63.8
Steam pressure - Standard	barG	6 - 9
	psiG	87-130.5
Steam inlet - steam outlet - Standard	BSPT- ISO7.1	3/4"
Steam inlet - condensate outlet	NPT ANSI B1.20.1 Tapered	3/4"
Steam consumption (5 bagG) - Low pressure	Kg/h	57
Steam consumption (72,5 psiG) - Low pressure	Lb/h	68.7
Steam pressure - Low Pressure	barG	3 - 6
	psiG	43.5 - 88
Steam Inlet - Steam Outlet - Low Pressure	BSPT - ISO7.1	1"

VENTILATION			
Nominal air flow	m³/h	1.200	
	cfm	706,29	
Air outlet Ø	mm	200	
	inch	7,87	
Fan motor power	kW	0,55	
HEAT DISSIPATION			
Total max heat dissipation	kW	0,96	
	kW	3277,6	
Front pannel max heat dissipation	Btu/h	0,6	
	Btu/h	2048,5	
CONNECTIONS		ELECTRICAL	GAS
Voltage 120/60/1~ I + G	Nº x AWG / A	-	3 X 12 / 20 A
Voltage 230V - 3~ + G	-	-	-
Voltage 480V - 3~ + G	-	-	-
DIMENSIONS / PACKING DIMENSIONS			
Net width / Gross width	mm	785 / 865	
	inch	30.91 / 34.06	
Net depth / Gross depth	mm	855 / 940	
	inch	33.66 / 37.01	
Net height / Gross height	mm	1694 / 1840	
	inch	66.69 / 72.44	
Net weight / Gross weight	Kg	172 / 180	
	Lb	379.26 / 396.83	
OTHERS			
Sound level	dB	64	

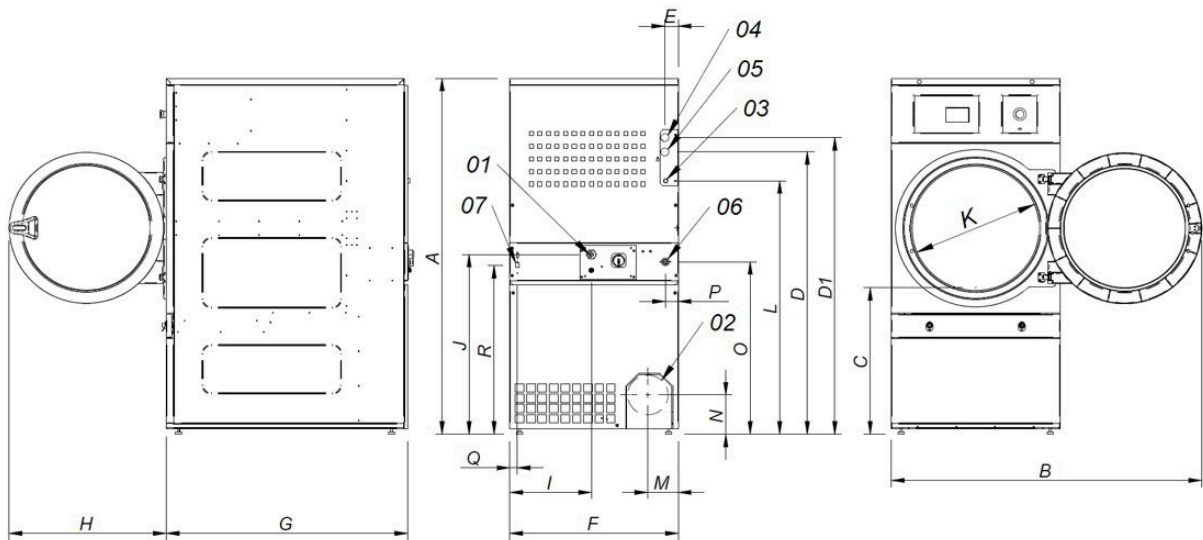

- 01. Power supply
- 02. Fumes output Ø200
- 03. Gas inlet 1/2"
- 04 Steam inlet 3/4"
- 05. Condensate outlet 3/4"
- 06. Sprinkler valve 3/4"
- 07. Ethernet connection

	A	B	C	D	D1	E	E1	F	G	H	I	J	K	L	M	N	O	P	Q	R
FD-25 TP2 PLUS	66.69	56.96	689	27.12	55.98	2.67	2.67	30.90	33.66	28.93	14.96	34.25	22.63	48.26	5.23	7.08	32.67	2.55	1.37	31.69

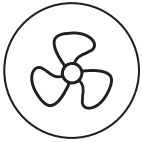

DRYING

SINGLE POCKET DRYERS ADVANCE+ -FD30 TP2 PLUS



CHARACTERISTICS

TP2

- 7" touchscreen, user friendly and totally programmable.
- Videos on display, ads, instructions.
- Free software for programming, telemetry, data analysis.
- USB Connection.
- 37 Languages.
- 8 dosing signals.

OUTSTANDING FEATURES

- Reversing drum action is standard.
- Stainless steel drum is standard.
- Frequency inverter is standard.

EFFICIENCY

- Intelligent humidity control with drum inlet temperature control.
- Efficient air recirculation system.
- Double door glass.
- Optimized system of mixed airflow.

VERSATILITY

- Make to order - customization.
- Wet Cleaning configuration.

CONNECTIVITY

- Standard IoT FagorKonnnect.
- Management of laundries: OPL and COIN.

ERGONOMICS

- Lint Filter Drawer, made of stainless steel.
- Large loading doors.

MAINTENANCE

- Hinged panel: easy and ergonomic access.
- Technical menu: statistics for technicians.

OTHERS

- Grey skin plate outer casing, stainless steel look.
- Integrated Fire Extinguishing System.
- Drum with stamped holes.
- Anti-wrinkle at the end of the cycle.
- Heating options: natural gas and propane.
- CE approved.

OPTIONS

- Opposite door opening.
- Tropicalized model.
- Dosing/spraying system.
- Back panel external air + filter.
- Fluff filter with grid 0,02 In (standard is 0,01 In).
- Fluff filter with grid 0.04 In (standard is 0,01 In).
- Stainless steel front and side panels
- Front panel in stainless steel

CAPACITY		
	U.	FD-30 TP2 PLUS
Capacity 1/18	Kg	15
	Lb	33.1
Capacity 1/20	Kg	13.5
	Lb	29.8
DRUM		
Ø Drum	mm	750
	inch	29.53
Drum length	mm	610
	inch	24.02
Drum volume	l cu	270
	ft	9.53
Ø Door	mm	574
	inch	22.6
Floor to door center	mm	976
	inch	38.43
Floor to lower part of the door	mm	618
	inch	24.33
Drum motor power	kW	0.37
ELECTRIC POWER		
Installed heating power	kW	18
Installed electrical power	kW	18.97
Evaporation capacity	l/h	14.5
	USgallon/h	3.8
Hourly output	Kg/h	29
	Lb/h	63.9
GAS POWER		
Installed heating power gas	Kcal/h	17638
	Btu/h	70000
Installed heating power gas	kW	20.51
Installed electrical power	kW	0.97
Instant propane gas consumption (G31)	Kg/h	1.76
	Lb/h	3.88
Instant natural gas consumption (G20)	m³/h	2.17
	cfm	1.28
Evaporation capacity	l/h	15.6
	USgallon/h	4.12
Hourly output Ø Gas inlet	Kg/h	32.5
	Lb/h	71.6
	BSPP ISO 228-1	1/2"
STEAM POWER		
Installed heating power steam	kW	30
	Btu/h	102364
Installed electrical power	kW	0.97
Steam consumption (8 barG) - Stándar	Kg/h	53
Steam consumption (116 psiG)	Lb/h	63.8
Steam pressure - Standard	barG	6 - 9
	psiG	87-130.5
Steam inlet - steam outlet - Standard	BSPT- ISO7.1	3/4"
Steam inlet - condensate outlet	NPT ANSI B1.20.1 Tapered	3/4"
Steam consumption (5 bagG) - Low pressure	Kg/h	57
Steam consumption (72,5 psiG) - Low pressure	Lb/h	68.7
Steam pressure - Low Pressure	barG	3 - 6
	psiG	43.5 - 90
Steam Inlet - Steam Outlet - Low Pressure	BSPT - ISO7.1	1"

VENTILATION			
Nominal air flow	m ³ /h	1200	
	cfm	706.29	
Air outlet Ø	mm	200	
	inch	7.87	
Fan motor power	kW	0.55	
HEAT DISSIPATION			
Total max heat dissipation	kW	1.44	
	kW	4916.4	
Front pannel max heat dissipation	Btu/h	0.9	
	Btu/h	3072.7	
CONNECTIONS		ELECTRICAL	STEAM / GAS
Voltage 120/60/1~ + G	N° x AWG / A	-	3 X 12 /20 A
Voltage 230V/3~ + G	-	-	-
Voltage 480V/3 ~ + G	-	-	-
DIMENSIONS / PACKING DIMENSIONS			
Net width / Gross width	mm	785 / 865	
	inch	30.91 / 34.06	
Net depth / Gross depth	mm	8989 / 1074	
	inch	38.93 / 42.28	
Net height / Gross height	mm	1694 / 1840	
	inch	66.69 / 72.44	
Net weight / Gross weight	Kg	180 / 190	
	Lb	396.83 / 418.88	
OTHERS			
Sound level	dB	65	

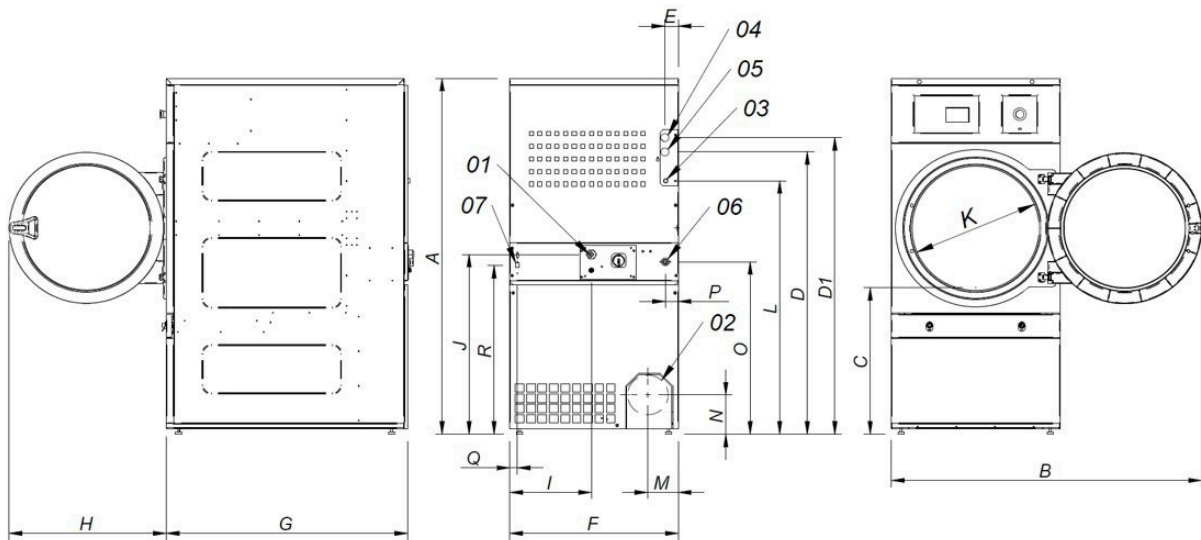

- 01. Power supply
- 02. Fumes output Ø200
- 03. Gas inlet 1/2"
- 04. Steam inlet 3/4"
- 05. Condensate outlet 3/4"
- 06. Sprinkler valve 3/4"
- 07. Ethernet connection

	A	B	C	D	D1	E	E1	F	G	H	I	J	K	L	M	N	O	P	Q	R
FD-30 TP2 PLUS	66.69	56.96	27.12	53.30	55.98	2.67	2.67	30.90	38.93	28.93	14.96	34.25	22.63	48.26	5.23	7.08	34.64	2.55	1.37	31.69



DRYING

SINGLE POCKET DRYERS ADVANCE+ FD-35 TP2 PLUS



CHARACTERISTICS

TP2

- 7" touchscreen, user friendly and totally programmable.
- Videos on display, ads, instructions.
- Free software for programming, telemetry, data analysis.
- USB Connection.
- 37 Languages.
- 8 dosing signals.

OUTSTANDING FEATURES

- Reversing drum action is standard.
- Stainless steel drum is standard.
- Frequency inverter is standard.

EFFICIENCY

- Intelligent humidity control with drum inlet temperature control.
- Efficient air recirculation system.
- Double door glass.
- Optimized system of mixed airflow.

VERSATILITY

- Make to order - customization.
- Wet Cleaning configuration.

CONNECTIVITY

- Standard IoT FagorKonnnect.
- Management of laundries: OPL and COIN.

ERGONOMICS

- Lint Filter Drawer, made of stainless steel.
- Large loading doors.

MAINTENANCE

- Hinged panel: easy and ergonomic access.
- Technical menu: statistics for technicians.

OTHERS

- Grey skin plate outer casing, stainless steel look.
- Integrated Fire Extinguishing System.
- Drum with stamped holes.
- Anti-wrinkle at the end of the cycle.
- Heating options: natural gas and propane.
- CE approved.

OPTIONS

- Opposite door opening.
- Tropicalized model.
- Dosing/spraying system.
- Back panel external air + filter.
- Fluff filter with grid 0,02 In (standard is 0,01 In).
- Fluff filter with grid 0.04 In (standard is 0,01 In).
- Stainless steel front and side panels
- Front panel in stainless steel

CAPACITY		U.	FD-35 TP2 PLUS
Capacity 1/18		Kg	18.3
		Lb	40.4
Capacity 1/20		Kg	16.5
		Lb	36.3
DRUM			
Ø Drum		mm	750
		inch	29.53
Drum length		mm	746
		inch	29.37
Drum volume		l cu	330
		ft	11.64
Ø Door		mm	574
		inch	22.6
Floor to door center		mm	976
		inch	38.43
Floor to lower part of the door		mm	618
		inch	24.33
Drum motor power		kW	0.37
ELECTRIC POWER			
Installed heating power		kW	18
Installed electrical power		kW	18.97
Evaporation capacity		l/h	14.90
		USgallon/h	3.94
Hourly output		Kg/h	30
		Lb/h	66.1
GAS POWER			
Installed heating power gas		Kcal/h	17638
		Btu/h	70000
Installed heating power gas		kW	20.51
Installed electrical power		kW	0.97
Instant propane gas consumption (G31)		Kg/h	1.76
		Lb/h	3.88
Instant natural gas consumption (G20)		m³/h	2.17
		cfm	1.28
Evaporation capacity		l/h	16.3
		USgallon/h	4.306
Hourly output Ø Gas inlet		Kg/h	33.6
		Lb/h	74.1
		BSPP ISO 228-1	1/2"
STEAM POWER			
Installed heating power steam		kW	30
		Btu/h	102364
Installed electrical power		kW	0.97
Steam consumption (8 barG) - Stándar		Kg/h	53
Steam consumption (116 psiG)		Lb/h	63.8
Steam pressure - Standard		barG	6 - 9
		psiG	87 - 130.5
Steam inlet - steam outlet - Standard		BSPT- ISO7.1	3/4"
Steam inlet - condensate outlet		NPT ANSI B1.20.1 Tapered	3/4"
Steam consumption (5 bagG) - Low pressure		Kg/h	57
Steam consumption (72,5 psiG) - Low pressure		Lb/h	68.7
Steam pressure - Low Pressure		barG	3 - 6
		psiG	43.5 - 92
Steam Inlet - Steam Outlet - Low Pressure		BSPT - ISO7.1	1"

VENTILATION			
Nominal air flow	m ³ /h	1200	
	cfm	706.29	
Air outlet Ø	mm	200	
	inch	7.87	
Fan motor power	kW	0.55	
HEAT DISSIPATION			
Total max heat dissipation	kW	1.44	
	kW	4916.4	
Front pannel max heat dissipation	Btu/h	0.9	
	Btu/h	3072.7	
CONNECTIONS		ELECTRICAL	GAS
Voltage 120/60/1~ + G	N° x AWG / A	-	3 X 12 /20 A
Voltage 230V/3~ + G	-	-	-
Voltage 480V/3 ~ + G	-	-	-
DIMENSIONS / PACKING DIMENSIONS			
Net width / Gross width	mm	785 / 865	
	inch	30.91 / 34.06	
Net depth / Gross depth	mm	1125 / 1210	
	inch	44.29 / 47.64	
Net height / Gross height	mm	1694 / 1840	
	inch	66.69 / 72.44	
Net weight / Gross weight	Kg	187 / 200	
	Lb	412.26 / 440.92	
OTHERS			
Sound level	dB	65	

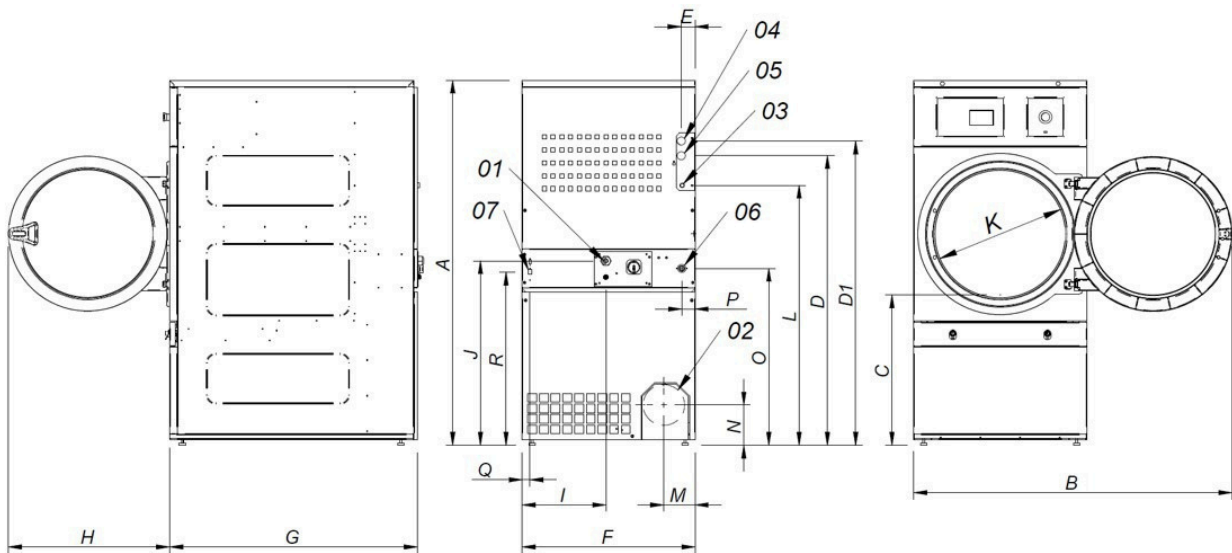

- 01. Power supply
- 02. Fumes output Ø200
- 03. Gas inlet 1/2"
- 04 Steam inlet 3/4" (1" FD-50)
- 05. Condensate outlet 3/4" (1" FD-50)
- 06. Sprinkler valve 3/4"
- 07. Ethernet connection

	A	B	C	D	D1	E	E1	F	G	H	I	J	K	L	M	N	O	P	Q	R
FD-35 TP2 PLUS	66.69	56.96	27.12	53.30	55.98	2.67	2.67	30.90	44.29	28.93	14.96	34.25	22.63	48.26	5.23	7.08	32.67	2.55	1.37	31.69



DRYING

SINGLE POCKET DRYERS ADVANCE+ FD-50 TP2 PLUS



CHARACTERISTICS

TP2

- 7" touchscreen, user friendly and totally programmable.
- Videos on display, ads, instructions.
- Free software for programming, telemetry, data analysis.
- USB Connection.
- 37 Languages.
- 8 dosing signals.

OUTSTANDING FEATURES

- Reversing drum action is standard.
- Stainless steel drum is standard.
- Frequency inverter is standard.

EFFICIENCY

- Intelligent humidity control with drum inlet temperature control.
- Efficient air recirculation system.
- Double door glass.
- Optimized system of mixed airflow.

VERSATILITY

- Make to order - customization.
- Wet Cleaning configuration.

CONNECTIVITY

- Standard IoT FagorKonnnect.
- Management of laundries: OPL and COIN.

ERGONOMICS

- Lint Filter Drawer, made of stainless steel.
- Large loading doors.

MAINTENANCE

- Hinged panel: easy and ergonomic access.
- Technical menu: statistics for technicians.

OTHERS

- Grey skin plate outer casing, stainless steel look.
- Integrated Fire Extinguishing System.
- Drum with stamped holes.
- Anti-wrinkle at the end of the cycle.
- Heating options: natural gas and propane.
- CE approved.

OPTIONS

- Opposite door opening.
- Tropicalized model.
- Dosing/spraying system.
- Back panel external air + filter.
- Fluff filter with grid 0,02 In (standard is 0,01 In).
- Fluff filter with grid 0.04 In (standard is 0,01 In).
- Stainless steel front and side panels
- Front panel in stainless steel

CAPACITY		
	U.	FD-50 TP2 PLUS
Capacity 1/18	Kg	24.3
	Lb	53.9
Capacity 1/20	Kg	22
	Lb	48.5
DRUM		
Ø Drum	mm	835
	inch	32.87
Drum length	mm	800
	inch	31.5
Drum volume	l cu	440
	ft	15.54
Ø Door	mm	574
	inch	22.6
Floor to door center	mm	1030
	inch	40.55
Floor to lower part of the door	mm	672
	inch	26.46
Drum motor power	kW	0.37
ELECTRIC POWER		
Installed heating power	kW	24
Installed electrical power	kW	25.17
Evaporation capacity	l/h	20
	USgallon/h	5,3
Hourly output	Kg/h	40
	Lb/h	88.2
GAS POWER		
Installed heating power gas	Kcal/h	26655
	Btu/h	105775.6
Installed heating power gas	kW	31
Installed electrical power	kW	1.17
Instant propane gas consumption (G31)	Kg/h	2.66
	Lb/h	5.86
Instant natural gas consumption (G20)	m³/h	3.28
	cfm	1.93
Evaporation capacity	l/h	22.3
	USgallon/h	5.89
Hourly output Ø Gas inlet	Kg/h	44.6
	Lb/h	98.3
	BSPP ISO 228-1	1/2"
STEAM POWER		
Installed heating power steam	kW	49.2
	Btu/h	167877
Installed electrical power	kW	1.17
Steam consumption (8 barG) - Stándar	Kg/h	87
Steam consumption (116 psiG)	Lb/h	104.8
Steam pressure - Standard	barG	6 - 9
	psiG	87 - 130.5
Steam inlet - steam outlet - Standard	BSPT- ISO7.1	1"
Steam inlet - condensate outlet	NPT ANSI B1.20.1 Tapered	1"
Steam consumption (5 bagG) - Low pressure	Kg/h	-
Steam consumption (72,5 psiG) - Low pressure	Lb/h	-
Steam pressure - Low Pressure	barG	3 - 6
	psiG	43.5 - 94
Steam Inlet - Steam Outlet - Low Pressure	BSPT - ISO7.1	1"

VENTILATION			
Nominal air flow	m ³ /h	1.500	
	cfm	882.87	
Air outlet Ø	mm	200	
	inch	7.87	
Fan motor power	kW	0.75	
HEAT DISSIPATION			
Total max heat dissipation	kW	1.92	
	kW	6555.1	
Front pannel max heat dissipation	Btu/h	1.2	
	Btu/h	4097	
CONNECTIONS		ELECTRICAL	STEAM / GAS
Voltage 120/60/1~ I + G	N° x AWG / A	-	3 X 12 /20 A
Voltage 230V - 3~ + G	-	-	-
Voltage 480V - 3~ + G	-	-	-
DIMENSIONS / PACKING DIMENSIONS			
Net width / Gross width	mm	890 / 970	
	inch	35.04 / 38.19	
Net depth / Gross depth	mm	1255 / 1345	
	inch	49.41 / 52.95	
Net height / Gross height	mm	1812 / 1940	
	inch	71.34 / 76.38	
Net weight / Gross weight	Kg	210 / 230	
	Lb	462.97 / 507.06	
OTHERS			
Sound level	dB	65	

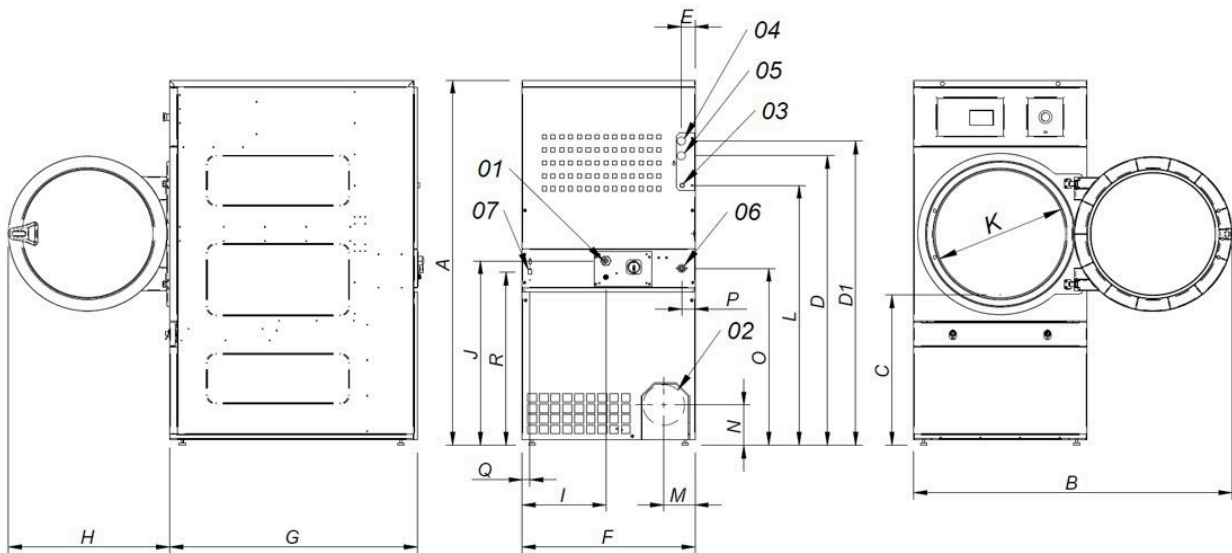

- 01. Power supply
- 02. Fumes output Ø200
- 03. Gas inlet 1/2"
- 04. Steam inlet 3/4" (1" FD-50)
- 05. Condensate outlet 3/4" (1" FD-50)
- 06. Sprinkler valve 3/4"
- 07. Ethernet connection

	A	B	C	D	D1	E	E1	F	G	H	I	J	K	L	M	N	O	P	Q	R
FD-50TP2 PLUS	71.33	61.10	29.25	56.21	60.31	4.40	2.16	35.03	49.40	28.93	4.21	36.22	22.63	52.91	9.37	7.08	34.84	2.55	1.45	33.85



DRYING

SINGLE POCKET DRYERS ADVANCE+ FD-65 TP2 PLUS



CHARACTERISTICS

TP2

- 7" touchscreen, user friendly and totally programmable.
- Videos on display, ads, instructions.
- Free software for programming, telemetry, data analysis.
- USB Connection.
- 37 Languages.
- 8 dosing signals.

OTHERS

- Grey skin plate outer casing, stainless steel look.
- Integrated Fire Extinguishing System.
- Drum with stamped holes.
- Anti-wrinkle at the end of the cycle.
- Heating options: natural gas and propane.
- CE approved.

OUTSTANDING FEATURES

- Reversing drum action is standard.
- Stainless steel drum is standard.
- Frequency inverter is standard.

OPTIONS

- Opposite door opening.
- Tropicalized model.
- Dosing/spraying system.
- Back panel external air + filter.
- Fluff filter with grid 0,02 In (standard is 0,01 In).
- Fluff filter with grid 0.04 In (standard is 0,01 In).
- Stainless steel front and side panels
- Front panel in stainless steel

EFFICIENCY

- Intelligent humidity control with drum inlet temperature control.
- Efficient air recirculation system.
- Double door glass.
- Optimized system of mixed airflow.

VERSATILITY

- Make to order - customization.
- Wet Cleaning configuration.

CONNECTIVITY

- Standard IoT FagorKonnnect.
- Management of laundries: OPL and COIN.

ERGONOMICS

- Lint Filter Drawer, made of stainless steel.
- Large loading doors.

MAINTENANCE

- Hinged panel: easy and ergonomic access.
- Technical menu: statistics for technicians.

CAPACITY		
	U.	FD-65 TP2 PLUS
Capacity 1/18	Kg	30.6
	Lb	67.3
Capacity 1/20	Kg	27.5
	Lb	60.6
DRUM		
Ø Drum	mm	947
	inch	37.28
Drum length	mm	780
	inch	30.71
Drum volume	l cu	550
	ft	19.42
Ø Door	mm	802
	inch	31.57
Floor to door center	mm	1040
	inch	40.94
Floor to lower part of the door	mm	578
	inch	22.74
Drum motor power	kW	0.55
ELECTRIC POWER		
Installed heating power	kW	30
Installed electrical power	kW	31.35
Evaporation capacity	l/h	26.8
	USgallon/h	7.1
Hourly output	Kg/h	51.6
	Lb/h	113.8
GAS POWER		
Installed heating power gas	Kcal/h	35276
	Btu/h	139986.5
Installed heating power gas	kW	41
Installed electrical power	kW	1.35
Instant propane gas consumption (G31)	Kg/h	3.51
	Lb/h	7.74
Instant natural gas consumption (G20)	m³/h	4.34
	cfm	2.55
Evaporation capacity	l/h	31.8
	USgallon/h	8.401
Hourly output Ø Gas inlet	Kg/h	61.1
	Lb/h	134.7
	BSPP ISO 228-1	1/2"
STEAM POWER		
Installed heating power steam	kW	50.1
	Btu/h	170948
Installed electrical power	kW	1.35
Steam consumption (8 barG) - Stándar	Kg/h	89
Steam consumption (116 psiG)	Lb/h	107.2
Steam pressure - Standard	barG	6 - 9
	psiG	87 - 130.5
Steam inlet - steam outlet - Standard	BSPT- ISO7.1	1"
Steam inlet - condensate outlet	NPT ANSI B1.20.1 Tapered	1"
Steam consumption (5 bagG) - Low pressure	Kg/h	93
Steam consumption (72,5 psiG) - Low pressure	Lb/h	112
Steam pressure - Low Pressure	barG	3 - 6
	psiG	43.5 - 96
Steam Inlet - Steam Outlet - Low Pressure	BSPT - ISO7.1	1 1/2"

VENTILATION			
Nominal air flow	m ³ /h	1500	
	cfm	882.87	
Air outlet Ø	mm	200	
	inch	7.87	
Fan motor power	kW	0.75	
HEAT DISSIPATION			
Total max heat dissipation	kW	2,4	
	kW	8193.9	
Front pannel max heat dissipation	Btu/h	1.5	
	Btu/h	5121.2	
CONNECTIONS		ELECTRICAL	GAS
Voltage 120/60/1~ + G	N° x AWG / A	-	3 X 12 / 20 A
Voltage 230V/3~ + G	-	-	-
Voltage 480V/3 ~ + G	-	-	-
DIMENSIONS / PACKING DIMENSIONS			
Net width / Gross width	mm	985 / 1065	
	inch	38.78 / 41.93	
Net depth / Gross depth	mm	1054 / 1154	
	inch	41.5 / 45.43	
Net height / Gross height	mm	1975 / 2080	
	inch	77.76 / 81.89	
Net weight / Gross weight	Kg	230 / 260	
	Lb	507.06 / 573.2	
OTHERS			
Sound level	dB	65	

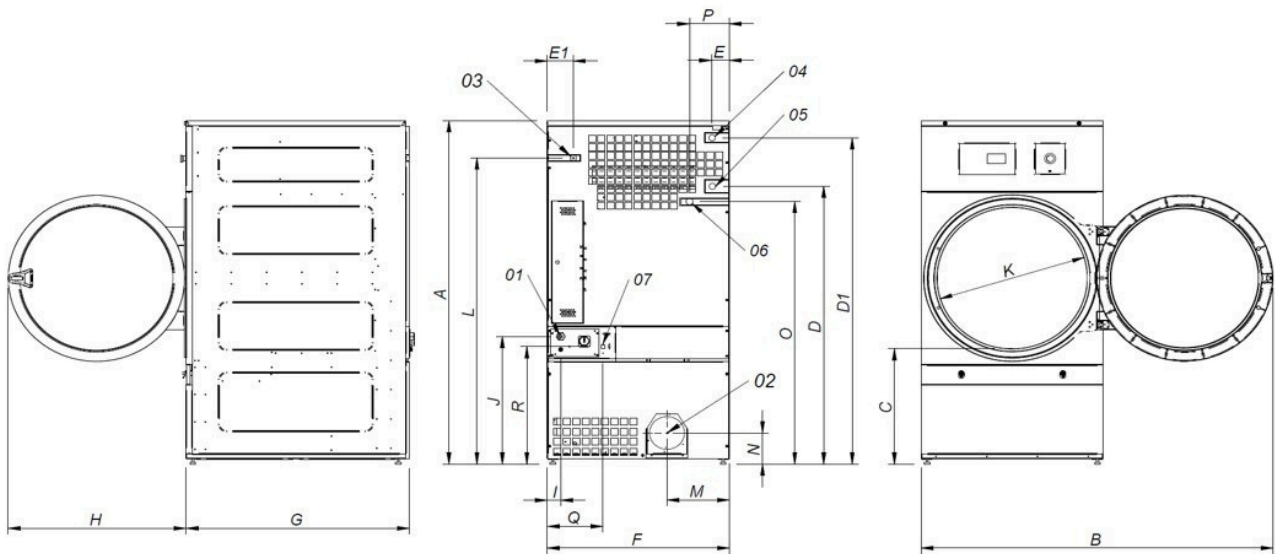

- 01. Power supply
- 02. Fumes output Ø200
- 03. Gas inlet 1/2"
- 04. Steam inlet 1"
- 05. Condensate outlet 1"
- 06. Sprinkler valve 3/4"
- 07. Ethernet connection

	A	B	C	D	D1	E	E1	F	G	H	I	J	K	L	M	N	O	P	Q	R
FD-65 TP2 PLUS	77.75	75.19	25.98	62.59	73.81	4.01	5.11	38.77	41.49	38.19	2.75	28.74	31.57	69.29	13.26	7.00	59.44	8.46	11.85	26.61



DRYING

SINGLE POCKET DRYERS ADVANCE+ FD-80 TP2 PLUS



CHARACTERISTICS

TP2

- 7" touchscreen, user friendly and totally programmable.
- Videos on display, ads, instructions.
- Free software for programming, telemetry, data analysis.
- USB Connection.
- 37 Languages.
- 8 dosing signals.

OUTSTANDING FEATURES

- Reversing drum action is standard.
- Stainless steel drum is standard.
- Frequency inverter is standard.

EFFICIENCY

- Intelligent humidity control with drum inlet temperature control.
- Efficient air recirculation system.
- Double door glass.
- Optimized system of mixed airflow.

VERSATILITY

- Make to order - customization.
- Wet Cleaning configuration.

CONNECTIVITY

- Standard IoT FagorKonnnect.
- Management of laundries: OPL and COIN.

ERGONOMICS

- Lint Filter Drawer, made of stainless steel.
- Large loading doors.

MAINTENANCE

- Hinged panel: easy and ergonomic access
- Technical menu: statistics for technicians.

OTHERS

- Grey skin plate outer casing, stainless steel look.
- Integrated Fire Extinguishing System.
- Drum with stamped holes.
- Anti-wrinkle at the end of the cycle.
- Heating options: natural gas and propane.
- CE approved.

OPTIONS

- Opposite door opening.
- Tropicalized model.
- Dosing/spraying system.
- Back panel external air + filter.
- Fluff filter with grid 0,02 In (standard is 0,01 In).
- Fluff filter with grid 0.04 In (standard is 0,01 In).
- Stainless steel front and side panels
- Front panel in stainless steel

CAPACITY		U.	FD-80 TP2 PLUS
Capacity 1/18	Kg		36.7
	Lb		80.8
Capacity 1/20	Kg		33
	Lb		72.8
DRUM			
Ø Drum	mm		947
	inch		37.28
Drum length	mm		936
	inch		36.85
Drum volume	l cu		660
	ft		23.3
Ø Door	mm		802
	inch		31.57
Floor to door center	mm		1040
	inch		40.94
Floor to lower part of the door	mm		578
	inch		22.74
Drum motor power	kW		0.55
ELECTRIC POWER			
Installed heating power	kW		36
Installed electrical power	kW		37.35
Evaporation capacity	l/h		31.5
	USgallon/h		8.3
Hourly output	Kg/h		63.9
	Lb/h		140.9
GAS POWER			
Installed heating power gas	Kcal/h		35276
	Btu/h		139986.5
Installed heating power gas	kW		41
Installed electrical power	kW		1.35
Instant propane gas consumption (G31)	Kg/h		3.51
	Lb/h		7.74
Instant natural gas consumption (G20)	m³/h		4.34
	cfm		2.55
Evaporation capacity	l/h		34.7
	USgallon/h		9.167
Hourly output Ø Gas inlet	Kg/h		73.3
	Lb/h		161.6
	BSPP ISO 228-1		1/2"
STEAM POWER			
Installed heating power steam	kW		50.1
	Btu/h		170948
Installed electrical power	kW		1.35
Steam consumption (8 barG) - Stándar	Kg/h		89
Steam consumption (116 psiG)	Lb/h		107.2
Steam pressure - Standard	barG		6 - 9
	psiG		87 - 130.5
Steam inlet - steam outlet - Standard	BSPT- ISO7.1		1"
Steam inlet - condensate outlet	NPT ANSI B1.20.1 Tapered		1"
Steam consumption (5 bagG) - Low pressure	Kg/h		93
Steam consumption (72,5 psiG) - Low pressure	Lb/h		112
Steam pressure - Low Pressure	barG		3 - 6
	psiG		43.5 - 98
Steam Inlet - Steam Outlet - Low Pressure	BSPT - ISO7.1		1 1/2"

VENTILATION			
Nominal air flow	m ³ /h	1500	
	cfm	882.87	
Air outlet Ø	mm	200	
	inch	7.87	
Fan motor power	kW	0.75	
HEAT DISSIPATION			
Total max heat dissipation	kW	2.88	
	kW	9832.7	
Front pannel max heat dissipation	Btu/h	1.8	
	Btu/h	6145.5	
CONNECTIONS		ELECTRICAL	GAS
Voltage 120/60/1~ + G	N° x AWG / A	-	3 X 12 /20 A
Voltage 230V/3~ + G	-	-	-
Voltage 480V/3 ~ + G	-	-	-
DIMENSIONS / PACKING DIMENSIONS			
Net width / Gross width	mm	985 / 1065	
	inch	38.78 / 41.93	
Net depth / Gross depth	mm	1210 / 1310	
	inch	47.64 / 51.57	
Net height / Gross height	mm	1975 / 2080	
	inch	77.76 / 81.89	
Net weight / Gross weight	Kg	260 / 285	
	Lb	573.20 / 628.32	
OTHERS			
Sound level	dB	65	

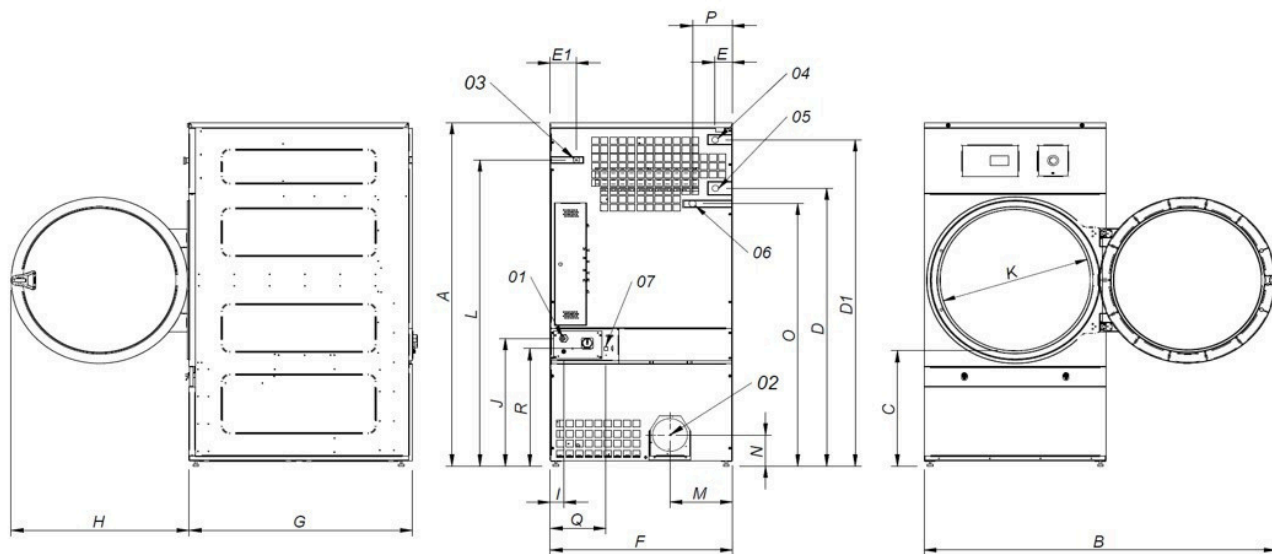

- 01. Power supply
- 02. Fumes output Ø200
- 03. Gas inlet 1/2"
- 04. Steam inlet 1"
- 05. Condensate outlet 1"
- 06. Sprinkler valve 3/4"
- 07. Ethernet connection

	A	B	C	D	D1	E	E1	F	G	H	I	J	K	L	M	N	O	P	Q	R
FD-80 TP2 PLUS	77.75	75.19	25.98	62.59	73.81	4.01	5.11	38.77	47.63	38.19	2.75	28.74	31.57	69.29	13.26	7.00	59.44	8.46	11.85	26.61



DRYING

SINGLE POCKET DRYERS ADVANCE+ FD100 TP2 PLUS



CHARACTERISTICS

TP2

- 7" touchscreen, user friendly and totally programmable.
- Videos on display, ads, instructions.
- Free software for programming, telemetry, data analysis.
- USB Connection.
- 37 Languages.
- 8 dosing signals.

OUTSTANDING FEATURES

- Reversing drum action is standard.
- Stainless steel drum is standard.
- Frequency inverter is standard.

EFFICIENCY

- Intelligent humidity control with drum inlet temperature control.
- Efficient air recirculation system.
- Complete air-flow circuit.
- Double door glass.
- Optimized system of mixed airflow.
- Large Lint filter.

VERSATILITY

- Make to order - customization.
- Wet Cleaning configuration.

CONNECTIVITY

- Standard IoT FagorKonnnect.
- Management of laundries: OPL and COIN.

ERGONOMICS

- Lint Filter Drawer, made of stainless steel.
- Large loading doors.

MAINTENANCE

- Hinged panel: easy and ergonomic access.
- Technical menu: statistics for technicians.

OTHERS

- Grey skin plate outer casing, stainless steel look.
- Integrated Fire Extinguishing System.
- Drum with stamped holes.
- Anti-wrinkle at the end of the cycle.
- Heating options: natural gas and propane.
- CE approved.

OPTIONS

- Automatic (double glass) or manual sliding door.
- Opposite door opening.
- Tropicalized model.
- Dosing/spraying system.
- Back panel external air + filter.
- Lint filter with grid 0,6mm (standard is 0,3mm).
- Lint filter with grid 1,2mm (standard is 0,3mm).
- Stainless steel front and side panels.
- Front panel in stainless steel.

CAPACITY		U.	FD-100 TP2 PLUS
Capacity 1/18	Kg		50
	Lb		110.2
Capacity 1/20	Kg		45
	Lb		99.2
DRUM			
Ø Drum	mm		1225
	inch		48.23
Drum length	mm		760
	inch		29.92
Drum volume	l cu		900
	ft		31.78
Ø Door	mm		802
	inch		31.57
Floor to door center	mm		1275
	inch		50.2
Floor to lower part of the door	mm		813
	inch		31.99
Drum motor power	kW		0.75
ELECTRIC POWER			
Installed heating power	kW		54
Installed electrical power	kW		57
Evaporation capacity	l/h		45
	USgallon/h		11.9
Hourly output	Kg/h		90
	Lb/h		198.4
GAS POWER			
Installed heating power gas	Kcal/h		51591
	Btu/h		204728.5
Installed heating power gas	kW		60
Installed electrical power	kW		3
Instant propane gas consumption (G31)	Kg/h		5.14
	Lb/h		11.33
Instant natural gas consumption (G20)	m³/h		6.35
	cfm		3.74
Evaporation capacity	l/h		48.2
	USgallon/h		12.73
Hourly output Ø Gas inlet	Kg/h		96.4
	Lb/h		212.5
	BSPP ISO 228-1		3/4"
STEAM POWER			
Installed heating power steam	kW		91
	Btu/h		310505
Installed electrical power	kW		3
Steam consumption (8 barG) - Stándar	Kg/h		121
Steam consumption (116 psiG)	Lb/h		145.8
Steam pressure - Standard	barG		7 - 12
	psiG		101.5 - 175
Steam inlet - steam outlet - Standard	BSPT - ISO7.1		1"
Steam inlet - condensate outlet	NPT ANSI B1.20.1 Tapered		1"
Steam consumption (5 bagG) - Low pressure	Kg/h		142
Steam consumption (72,5 psiG) - Low pressure	Lb/h		171.1
Steam pressure - Low Pressure	barG		4 - 7
	psiG		58 - 101.5
Steam Inlet - Steam Outlet - Low Pressure	BSPT - ISO7.1		1" 1/2

THERMAL OIL			
Installed heating power	kW	91	
Installed electrical power	kW	3.7	
Fluid consumption (T max 175°C)	m³/h	1"	
Connections thermal oil	BSP	1/2	
VENTILATION			
Nominal air flow	m³/h	4500	
	cfm	2648.6	
Air outlet Ø	mm	300	
	inch	11.81	
Fan motor power	kW	2.2	
HEAT DISSIPATION			
Total max heat dissipation	kW	3.78	
	Btu/h	12905.	
Front pannel max heat dissipation	kW	4.108	
	Btu/h	3687.3	
CONNECTIONS	ELECTRICAL	GAS	
Voltage 208-240/60/1~ + G	-	-	
Voltage 230V /3~ + G	Nº x mm2 / A	-	4x12 / 20 A
Voltage 440-480V /3~ +G	Nº x mm2 / A	-	4X14 / 15 A
DIMENSIONS / PACKING DIMENSIONS			
Net width / Gross width	mm	1.270 / 1.330	
	inch	50 / 52,36	
Net depth / Gross depth	mm	1.106 / 1.185	
	inch	43,54 / 46.65	
Net height / Gross height	mm	2.380 / 2.200	
	inch	93,70 / 86,61	
Net weight / Gross weight	Kg	395 / 430	
	Lb	870,83 / 947,99	
OTHERS			
Sound level	dB	67	

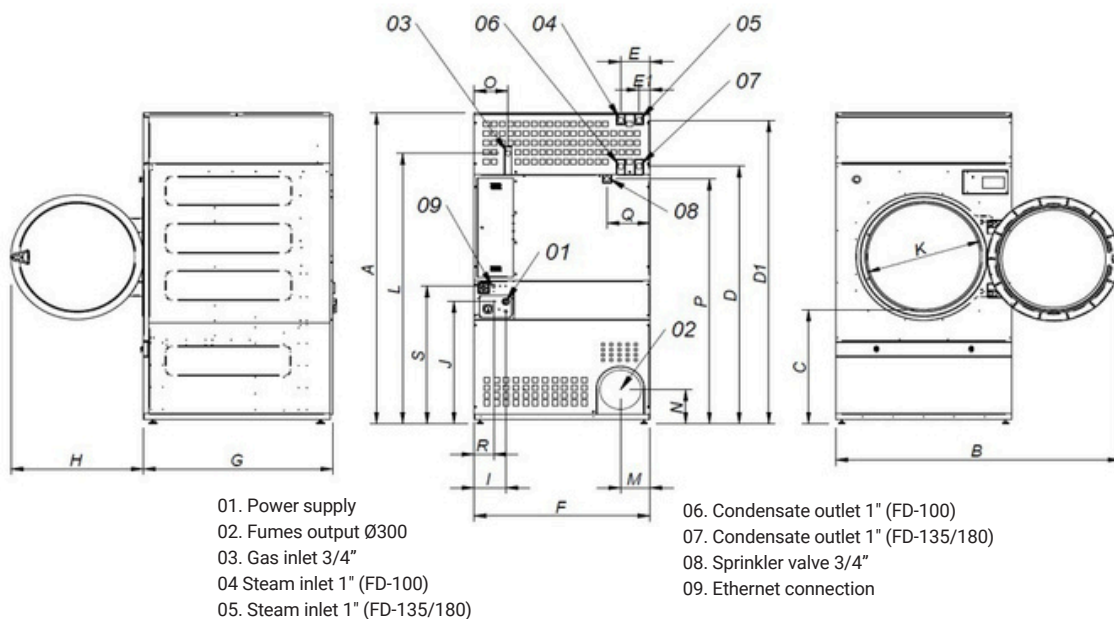

	A	B	C	D	D1	E	E1	F	G	H	I	J	K	L	M	N	O	P	Q	R	S
FD-100 TP2 PLUS	93.70	80.51	34.40	77.99	90.98	8.30	3.14	50	43.54	37.63	9.76	36.81	31.57	82.20	8.4	9.44	9.60	72.48	12.12	6.29	41.55



DRYING

SINGLE POCKET DRYERS ADVANCE+ FD 135 TP2 PLUS



CHARACTERISTICS

TP2

- 7" touchscreen, user friendly and totally programmable.
- Videos on display, ads, instructions.
- Free software for programming, telemetry, data analysis.
- USB Connection.
- 37 Languages.
- 8 dosing signals.

OUTSTANDING FEATURES

- Reversing drum action is standard.
- Stainless steel drum is standard.
- Frequency inverter is standard.

EFFICIENCY

- Intelligent humidity control with drum inlet temperature control.
- Efficient air recirculation system.
- Complete air-flow circuit.
- Double door glass.
- Optimized system of mixed airflow.
- Large Lint filter.

VERSATILITY

- Make to order - customization.
- Wet Cleaning configuration.

CONNECTIVITY

- Standard IoT FagorKonnnect.
- Management of laundries: OPL and COIN.

ERGONOMICS

- Lint Filter Drawer, made of stainless steel.
- Large loading doors.

MAINTENANCE

- Hinged panel: easy and ergonomic access.
- Technical menu: statistics for technicians.

OTHERS

- Grey skin plate outer casing, stainless steel look.
- Integrated Fire Extinguishing System.
- Drum with stamped holes.
- Anti-wrinkle at the end of the cycle.
- Heating options: natural gas and propane.
- CE approved.

OPTIONS

- Automatic (double glass) or manual sliding door.
- Opposite door opening.
- Tropicalized model.
- Dosing/spraying system.
- Back panel external air + filter.
- Lint filter with grid 0,6mm (standard is 0,3mm).
- Lint filter with grid 1,2mm (standard is 0,3mm).
- Stainless steel front and side panels.
- Front panel in stainless steel.

CAPACITY		U	FD-135 TP2 PLUS
Capacity 1/18	Kg		66.7
	Lb		146.9
Capacity 1/20	Kg		60
	Lb		132.3
DRUM			
Ø Drum	mm		1225
	inch		48.23
Drum length	mm		1020
	inch		40.16
Drum volume	l cu		1200
	ft		42.37
Ø Door	mm		802
	inch		31.57
Floor to door center	mm		1275
	inch		50.2
Floor to lower part of the door	mm		813
	inch		31.99
Drum motor power	kW		1.1
ELECTRIC POWER			
Installed heating power	kW		72
Installed electrical power	kW		75.35
Evaporation capacity	l/h		64
	USgallon/h		16.91
Hourly output	Kg/h		128.6
	Lb/h		283.5
GAS POWER			
Installed heating power gas	Kcal/h		77386
	Btu/h		307092.7
Installed heating power gas	kW		90
Installed electrical power	kW		3.35
Instant propane gas consumption (G31)	Kg/h		7.71
	Lb/h		17
Instant natural gas consumption (G20)	m³/h		9.53
	cfm		5.61
Evaporation capacity	l/h		72
	USgallon/h		19.02
Hourly output Ø Gas inlet	Kg/h		144
	Lb/h		317.5
	BSPP ISO 228-1		3/4"
STEAM POWER			
Installed heating power steam	kW		128
	Btu/h		436754
Installed electrical power	kW		3.35
Steam consumption (8 barG) - Stándar	Kg/h		171
Steam consumption (116 psiG)	Lb/h		206
Steam pressure - Standard	barG		7 - 12
	psiG		101.5 - 177
Steam inlet - steam outlet - Standard	BSPT - ISO7.1		1"
Steam inlet - condensate outlet	NPT ANSI B1.20.1 Tapered		1"
Steam consumption (5 bagG) - Low pressure	Kg/h		147
Steam consumption (72,5 psiG) - Low pressure	Lb/h		177.1
Steam pressure - Low Pressure	barG		4 - 7
	psiG		58 - 101.5
Steam Inlet - Steam Outlet - Low Pressure	BSPT - ISO7.1		1" 1/2

THERMAL OIL			
Installed heating power	kW	128	
Installed electrical power	kW	3.35	
Fluid consumption (T max175°C)	m³/h	10 1"	
Connections thermal oil	BSP	1/2	
VENTILATION			
Nominal air flow	m³/h	4500	
	cfm	2648.6	
Air outlet Ø	mm	300	
	inch	11.81	
Fan motor power	kW	2.2	
HEAT DISSIPATION			
Total max heat dissipation	kW	5.04	
	Btu/h	17207.3	
Front pannel max heat dissipation	kW	1.44	
	Btu/h	4916.4	
CONNECTIONS		ELECTRICAL	GAS
Voltage 208-240/60/1~ + G	-	-	-
Voltage 230V /3~ + G	Nº x mm2 / A	-	4x10 / 25 A
Voltage 440-480V /3~ +G	Nº x mm2 / A	-	4x14/ 15 A
DIMENSIONS / PACKING DIMENSIONS			
Net width / Gross width	mm	1270 / 1330	
	inch	50 / 52.36	
Net depth / Gross depth	mm	1366 / 1455	
	inch	53.78 / 57.28	
Net height / Gross height	mm	2380 / 2200	
	inch	93.7 / 86.61	
Net weight / Gross weight	Kg	529 / 575	
	Lb	1166.25 / 1267.66	
OTHERS			
Sound level	dB	67	

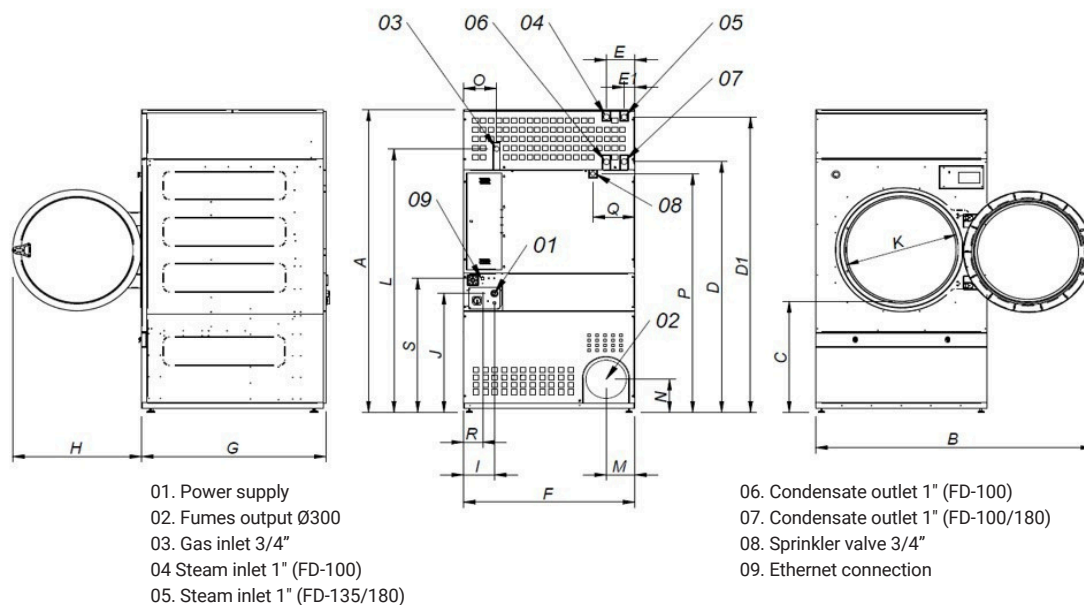

	A	B	C	D	D1	E	E1	F	G	H	I	J	K	L	M	N	O	P	Q	R	S
FD-135 TP2 PLUS	93.70	80.51	34.40	77.99	90.98	8.30	3.14	50	53.77	37.63	9.76	36.81	31.57	82.20	8.4	9.44	9.60	72.48	12.12	6.29	41.55



DRYING

SINGLE POCKET DRYERS ADVANCE+ FD 180 TP2 PLUS



CHARACTERISTICS

TP2

- 7" touchscreen, user friendly and totally programmable.
- Videos on display, ads, instructions.
- Free software for programming, telemetry, data analysis.
- USB Connection.
- 37 Languages.
- 8 dosing signals.

OUTSTANDING FEATURES

- Reversing drum action is standard.
- Stainless steel drum is standard.
- Frequency inverter is standard.

EFFICIENCY

- Intelligent humidity control with drum inlet temperature control.
- Efficient air recirculation system.
- Complete air-flow circuit.
- Double door glass.
- Optimized system of mixed airflow.
- Large Lint filter.

VERSATILITY

- Make to order - customization.
- Wet Cleaning configuration.

CONNECTIVITY

- Standard IoT FagorKonnnect.
- Management of laundries: OPL and COIN.

ERGONOMICS

- Lint Filter Drawer, made of stainless steel.
- Large loading doors.

MAINTENANCE

- Hinged panel: easy and ergonomic access.
- Technical menu: statistics for technicians.

OTHERS

- Grey skin plate outer casing, stainless steel look.
- Integrated Fire Extinguishing System.
- Drum with stamped holes.
- Anti-wrinkle at the end of the cycle.
- Heating options: natural gas and propane.
- CE approved.

OPTIONS

- Automatic (double glass) or manual sliding door.
- Opposite door opening.
- Tropicalized model.
- Dosing/spraying system.
- Back panel external air + filter.
- Lint filter with grid 0,6mm (standard is 0,3mm).
- Lint filter with grid 1,2mm (standard is 0,3mm).
- Stainless steel front and side panels.
- Front panel in stainless steel.

CAPACITY		U.	FD-180 TP2 PLUS
Capacity 1/18	Kg		83.3
	Lb		183.6
Capacity 1/20	Kg		75
	Lb		165.3
DRUM			
Ø Drum	mm		1225
	inch		48.23
Drum length	mm		1252
	inch		49.29
Drum volume	l cu		1500
	ft		52.95
Ø Door	mm		802
	inch		31.57
Floor to door center	mm		1275
	inch		50.2
Floor to lower part of the door	mm		813
	inch		31.99
Drum motor power	kW		1.5
ELECTRIC POWER			
Installed heating power	kW		72
Installed electrical power	kW		75.75
Evaporation capacity	l/h		68.2
	USgallon/h		18.02
Hourly output	Kg/h		136.4
	Lb/h		300.7
GAS POWER			
Installed heating power gas	Kcal/h		103181
	Btu/h		409456.9
Installed heating power gas	kW		120
Installed electrical power	kW		3.75
Instant propane gas consumption (G31)	Kg/h		10.28
	Lb/h		22.66
Instant natural gas consumption (G20)	m³/h		12.71
	cfm		7.48
Evaporation capacity	l/h		93.8
	USgallon/h		24.78
Hourly output Ø Gas inlet	Kg/h		187.5
	Lb/h		413.4
	BSPP ISO 228-1		3/4"
STEAM POWER			
Installed heating power steam	kW		128
	Btu/h		436754
Installed electrical power	kW		3.75
Steam consumption (8 barG) - Stándar	Kg/h		171
Steam consumption (116 psiG)	Lb/h		206
Steam pressure - Standard	barG		7 - 12
	psiG		101.5 - 179
Steam inlet - steam outlet - Standard	BSPT - ISO7.1		1"
Steam inlet - condensate outlet	NPT ANSI B1.20.1 Tapered		1"
Steam consumption (5 bagG) - Low pressure	Kg/h		147
Steam consumption (72,5 psiG) - Low pressure	Lb/h		177,1
Steam pressure - Low Pressure	barG		4 - 7
	psiG		58 - 101.5
Steam Inlet - Steam Outlet - Low Pressure	BSPT - ISO7.1		1" 1/2

THERMAL OIL			
Installed heating power	kW	128	
Installed electrical power	kW	3,75	
Fluid consumption (T max175°C)	m³/h	10 1"	
Connections thermal oil	BSP	1/2	
VENTILATION			
Nominal air flow	m³/h	4500	
	cfm	2648.6	
Air outlet Ø	mm	300	
	inch	11.81	
Fan motor power	kW	2.2	
HEAT DISSIPATION			
Total max heat dissipation	kW	5.04	
	Btu/h	17207.3	
Front pannel max heat dissipation	kW	1.44	
	Btu/h	4916.4	
CONNECTIONS		ELECTRICAL	GAS
Voltage 208-240/60/1~ + G		-	-
Voltage 230V /3~ + G		Nº x mm2 / A	4x10 / 25 A
Voltage 440-480V /3~ +G		Nº x mm2 / A	4x14/ 15 A
DIMENSIONS / PACKING DIMENSIONS			
Net width / Gross width	mm	1270 / 1330	
	inch	50 / 52.36	
Net depth / Gross depth	mm	1598 / 1705	
	inch	62.91 / 67.13	
Net height / Gross height	mm	2380 / 2200	
	inch	93.7 / 86.61	
Net weight / Gross weight	Kg	657 / 715	
	Lb	1448.44 / 1576.31	
OTHERS			
Sound level	dB	67	

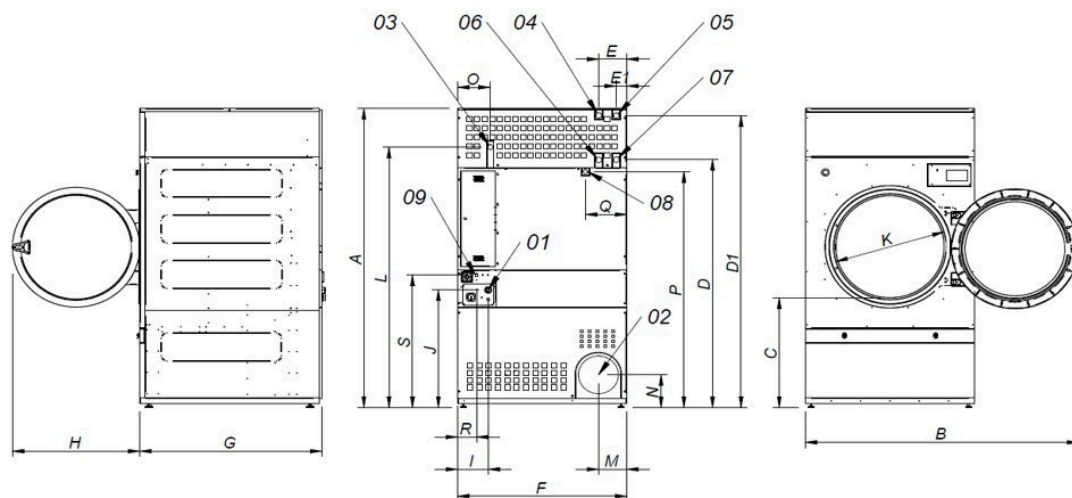

- 01. Power supply
- 02. Fumes output Ø300
- 03. Gas inlet 3/4"
- 04 Steam inlet 1" (SR-45)
- 05. Steam inlet 1" (SR-60/80)
- 06. Condensate outlet 1" (SR-45)
- 07. Condensate outlet 1" (SR-60/80)
- 08. Sprinkler valve 3/4"
- 09. Ethernet connection

	A	B	C	D	D1	E	E1	F	G	H	I	J	K	L	M	N	O	P	Q	R	S
FD-100 TP2 PLUS	93.70	80.51	34.40	77.99	90.98	8.30	3.14	50	62.91	37.63	9.76	36.81	31.57	82.20	8.4	9.44	9.60	72.48	12.12	6.29	41.55